

Intro to CAD - Onshape

Team 21380
Beyond Robotics

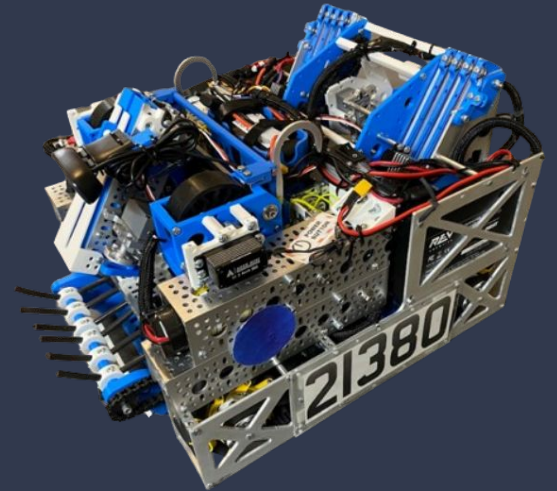

Intro

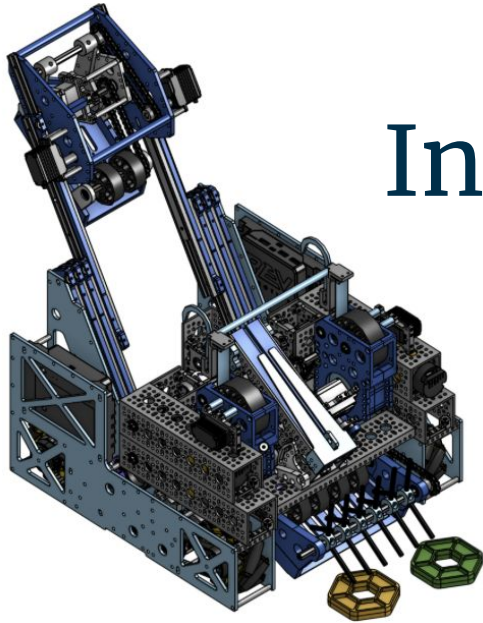

- **Who are we?**
 - We are Team Beyond Robotics 21380, established in July 2022. Our team is based in San Marino, and we compete in League C1, La Cañada.
- **Competition History**
 - Powerplay: Ranked #1 NP-OPR in SoCal
 - ILT: WAC, Motivate
 - Champs: FAC, Control 3rd
 - CenterStage: Ranked #1 NP-OPR in SoCal
 - ILT: Inspire 3rd, WAC, Design, Promote, Compass 3rd
 - Champs: Think 3rd, Compass
- **We are always open to questions or team connecting! You can contact us via Email or Instagram**
 - Email: contact@beyondrobotics.org
 - Insta: [@beyond_robotics_team](https://www.instagram.com/beyond_robotics_team)
 - Website: beyondrobotics.org

Engineering Design Process

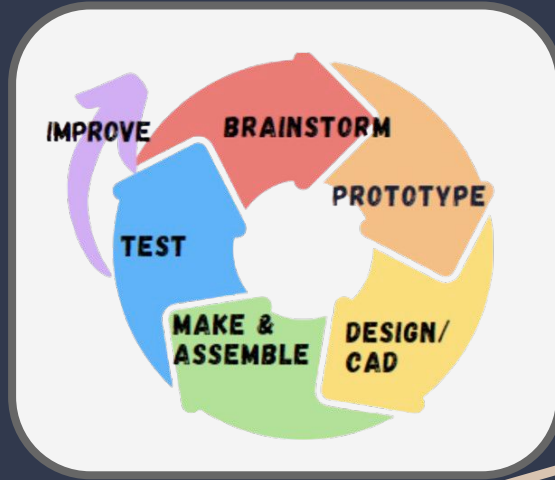

- **Brainstorm**
 - Brainstorm ideas after analyzing the game.
 - Decide on the pros and cons of the ideas and choose one to base the prototype off of.
- **Prototype**
 - Run tests using the prototype to see whether or not our design is viable
- **Design and CAD**
 - Analyze the flaws and pros of the prototype and improve the design through 3D designing tools such as Onshape.
- **Build**
 - Build the bot using parts 3D printed out and from parts from goBilda and REV Robotics
- **Test**
 - Test the bot in a imitation match to see how it behaves, and afterward, brainstorm ways to improve the design.

What is CAD?



- **What is CAD (Computer Aided Design)?**
 - Short for Computer Aided Design
 - Programs that allow you to design 3D models
- **Why Use CAD?**
 - Make 3D models of robots and simulate movements
 - Design custom parts for 3D printing/laser cutting
 - Share and document design ideas

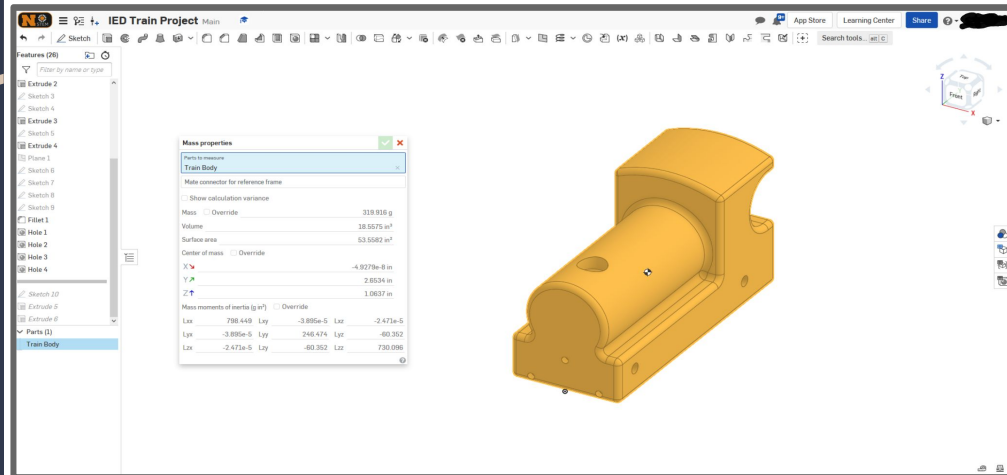

Centerstage Design Showcase

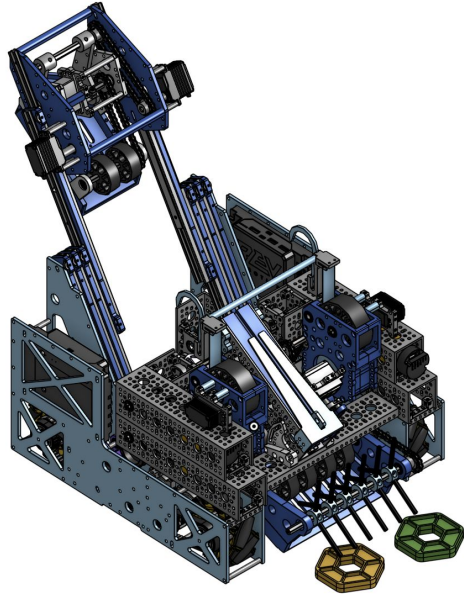

- **Our CenterStage Robot**

- **Outtake**

- Releases pixels on backdrop
- Compliance wheels
- 3d printed pixel holder

- **Intake**

- Takes in the pixels to the outtake
- 3d printed ramp
- Tubing

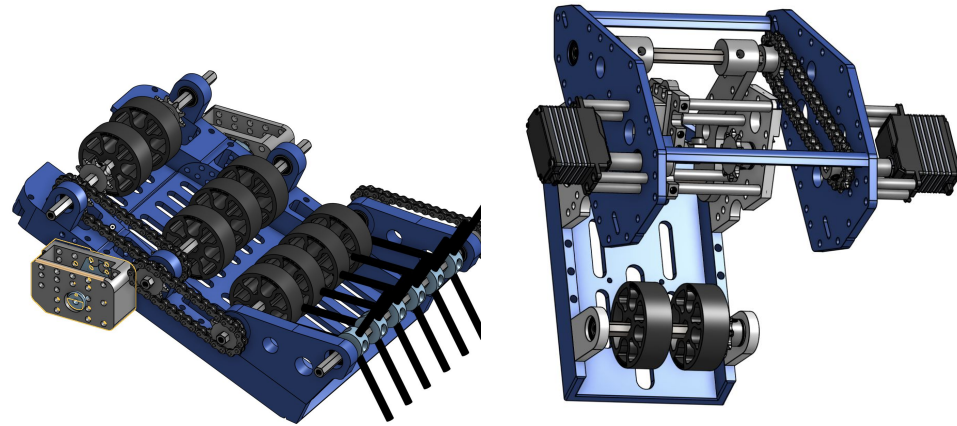

Centerstage Design Showcase

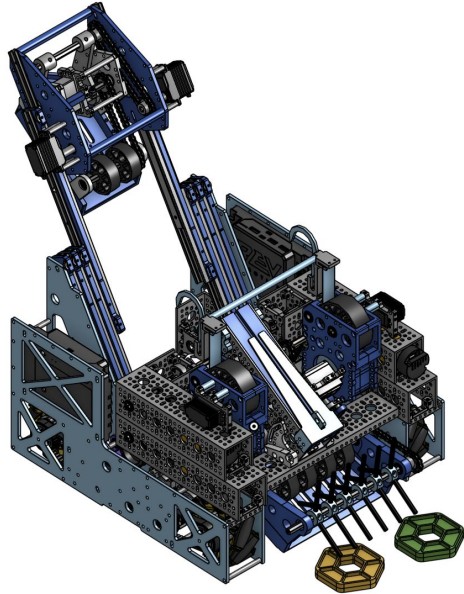

- **Launcher**
 - Launches the airplane
 - Scotch Yoke Mechanism
- **Mecanum Drive Train, Slide**
 - Odometry
 - 4-stage linear slide
- **Hanger**
 - Hangs the Robot
 - Laser cut hooks
 - Tape measure

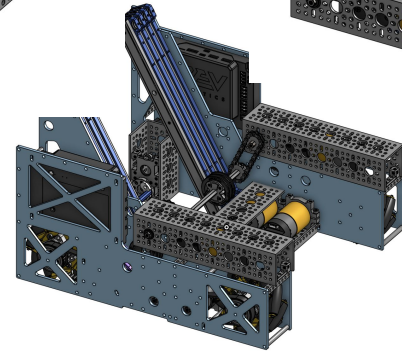
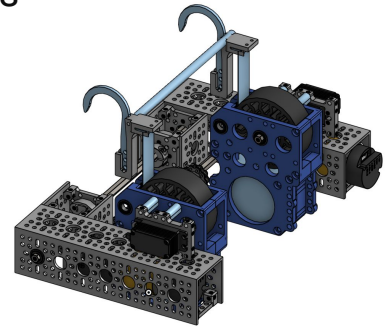
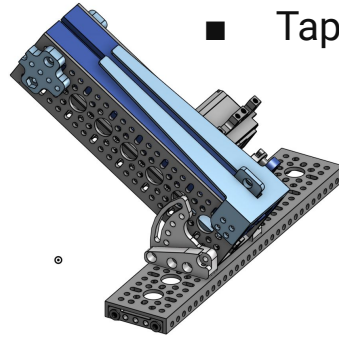

Beyond Robotics Centerstage Robot

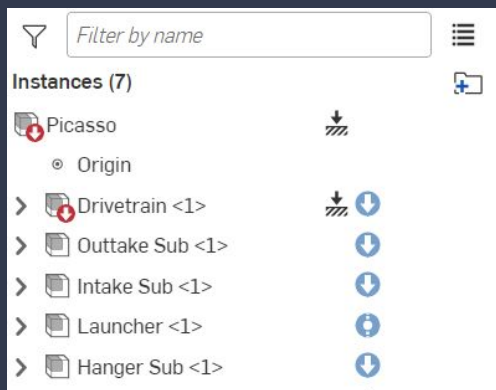

Picasso Demo

- **Onshape View Control**
 - Zoom
 - Pan
 - Rotate
- **Camera Options**
 - Top/Front/Right
 - Isometric to reset

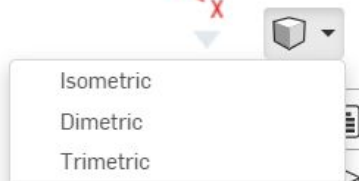
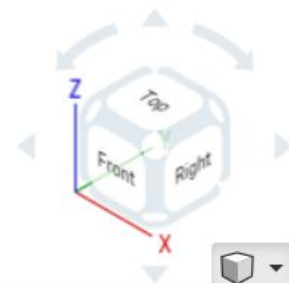

- **Picasso and Its Sub-assemblies**



- **Simulate Robot Movements**
 - Slide Up/Down
 - Intake
 - Adjust Launcher Angle

Onshape CAD Steps for FTC

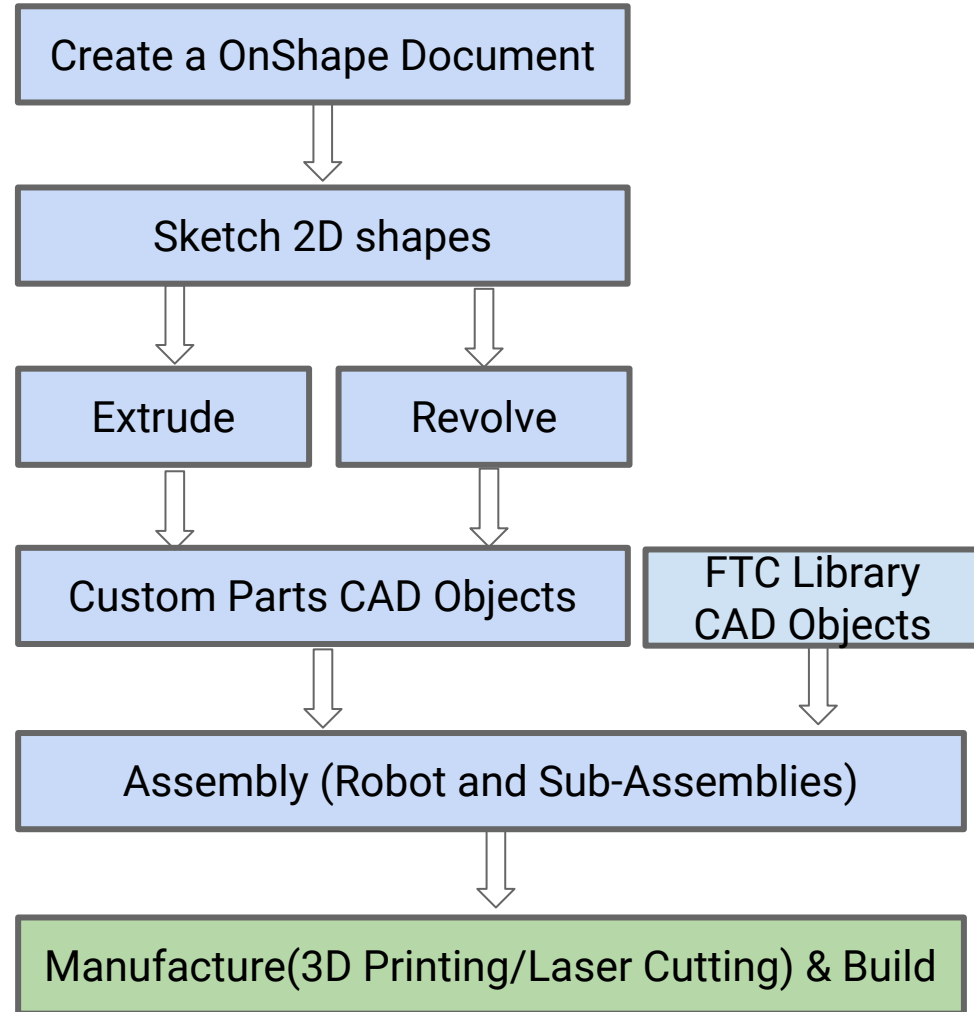
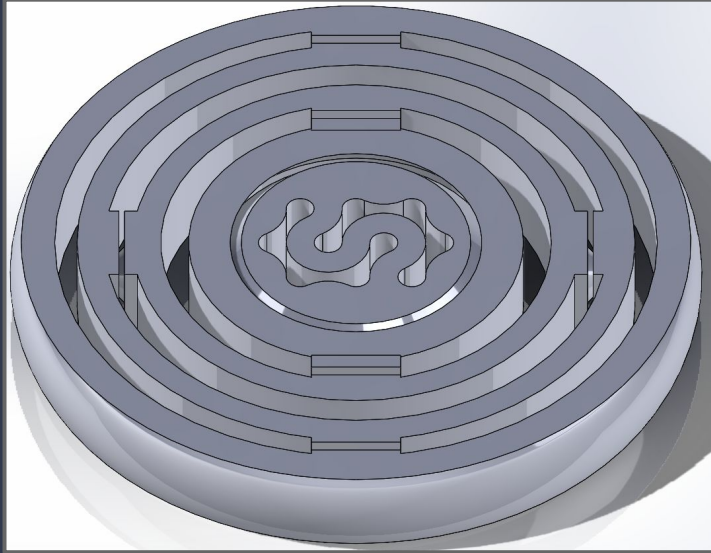

Revolve

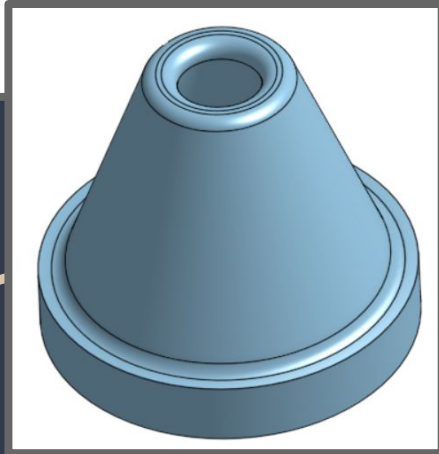
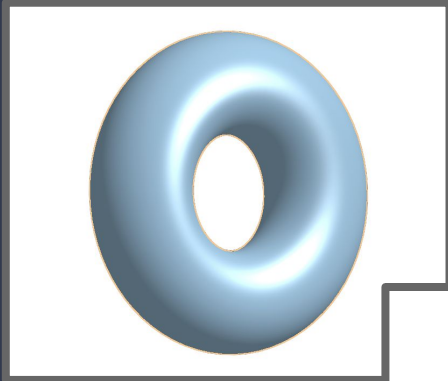

- **Revolve**
 - Revolving is an important tool when it comes to creating a **ROUND** object
 - similar to an extrude, except that it requires an axis line to go around
 - Revolve allows us to create more complex shapes using curves
 - Examples:
 - Donuts, cones, cylinders with an empty hole, and spheres.

Onshape Part Studio

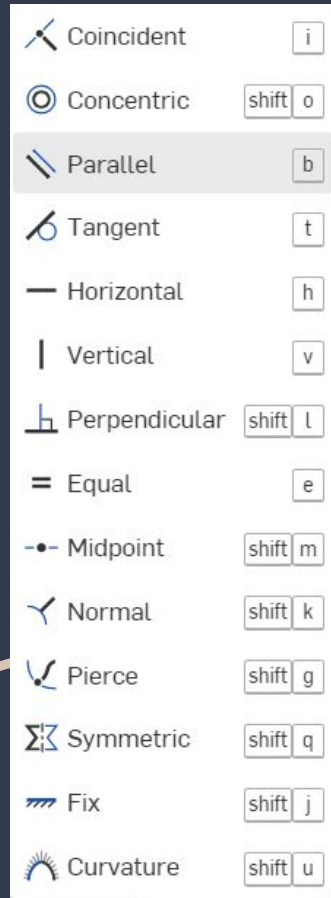

○ **New Document**

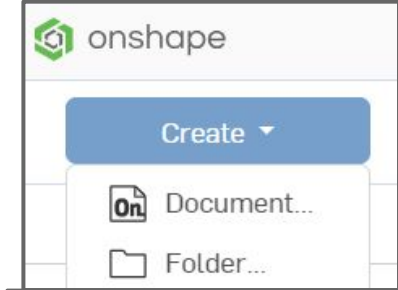

○ **New Sketch**

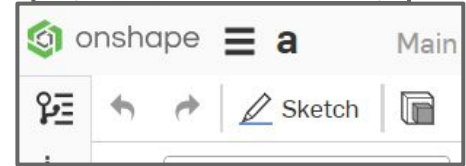

○ **Basic Shapes**



○ **Sketch Constraints**

○ **Sketch Dimensions**

○ **Extrude**

- New
- Add
- Remove

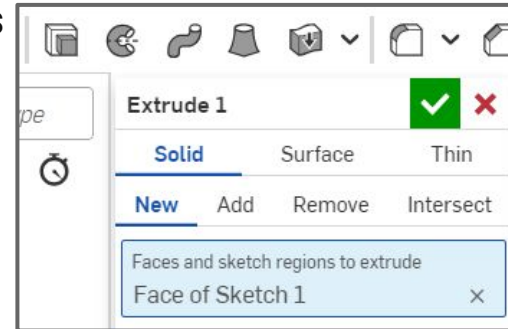

○ **Revolve**

- Cone
- Donut

Assembly

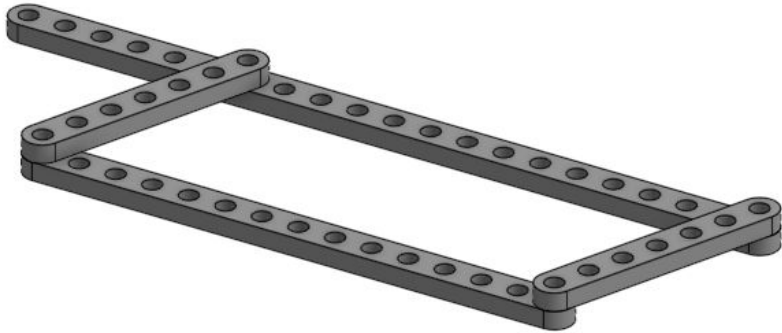

What are assemblies used for?

- Simulating movement in your mechanisms
- Demonstrates interactions between many mates pretty well
- Allows you to incorporate part files and other assemblies into a larger assembly
- Easy connection through mates.
- Mates are easy and quick to make

Mates

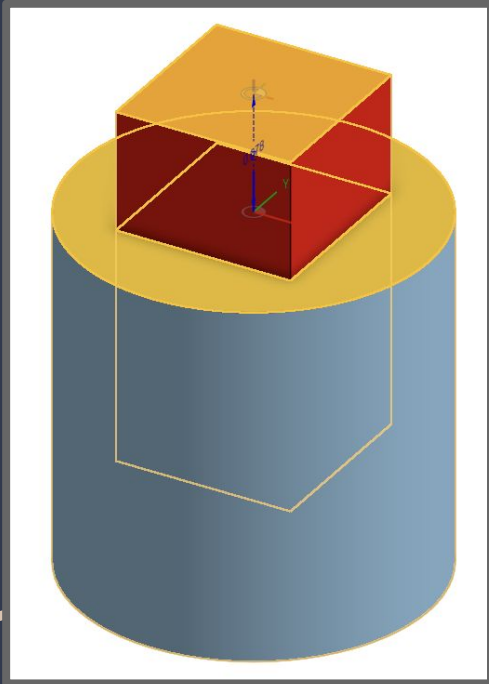

Mates

- Fastened mate
 - Doesn't allow for any motion
- Slider mate
 - Allows for linear motion along an axis
- Revolute mate
 - Allows for rotational motion along an axis
- Cylindrical mate
 - Allows for both rotational motion and linear motion along an axis

3D Printing

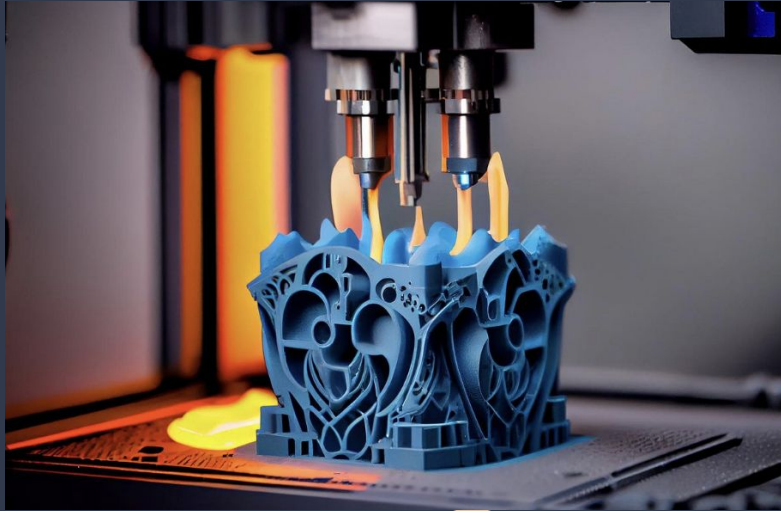

- **What is 3D Printing?**

3D printing is an additive process of creating 3D prints from layers and layers of PLA. 3D printing can only be done after you have created a model or have found a model and then download the file so that it can be uploaded to a 3D printer.

- **Why is 3D Printing Important in FTC?**

3D printing is important in FTC because sometimes you can't find the exact part that you want so you have to create your own custom part. 3D printing is also important to create game pieces for the game.

3D Printers



- **Bambu Lab P1S 3D Printer**
 - Cost: \$849
 - Efficiency: 500 mm/s
 - Filament Slots: 4
 - Print Height: 250 mm
 - High cost, fast speed, good print space, multi color
- **Creality Ender 3 V3 SE 3D Printer**
 - Cost: \$219
 - Efficiency: 250 mm/s
 - Filament Slots: 1
 - Print Height 220 mm
 - Low cost, mediocre speed, good print space, single color
- **XYZ Da Vinci 1.0 Pro**
 - Cost: \$899
 - Efficiency: 150 mm/s
 - Filament Slots: 3
 - Print Height: 200 mm
 - We have not tested this printer yet

CAD Resources

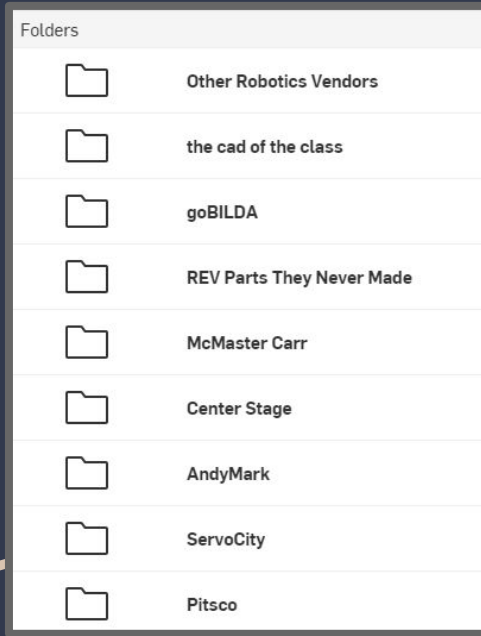

- **Onshape Learning Center**
 - Onshape has free educational resources, including self-paced courses, videos, and articles.
 - <https://learn.onshape.com/>
- **FTC Part Library**
 - Team 2901 created an Onshape Parts Library and has put together a library of parts from ServoCity, GoBilda, Pitsco, AndyMark, and Rev Robotics.
 - For access, email FIRST@ptc.com and state the email addresses of every team member who would like access.

CAD Tips



- **Tips**

- Try to use the FTC Part Library as much as possible.
- Keep tabs for higher leveled assemblies and also make as few parts studios as possible
- Use one folder per subsystem
- Join FTC CAD discord and ask questions.
- Don't be afraid of making mistakes.
- **!! Most important: Practice a lot!**

Making an OnShape Account & Team Management

Onshape is a professional-grade, cloud-native CAD platform that students and educators can access for FREE on any device, anywhere, anytime.

CREATE EDU ACCOUNT

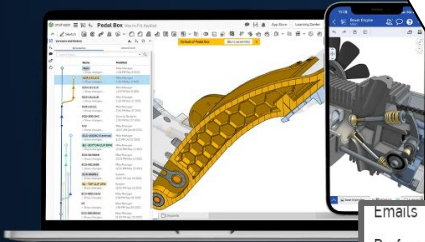

1

WE ARE PROUD TO PARTNER WITH:



- Emails
- Preferences
- Notifications
- Security
- Devices
- Applications
- Integrations
- Subscription
- Payment options
- Payment history
- Teams**
- Subscription: Student

● How to sign up for OnShape

- You can get a free education account as a student.
 - Once you registered your account, you can create teams.
 - Then, you can add team members by their emails.
 - Finally, you can set up roles, such as member or admin

2

FTC 21380 Team

Team name:

FTC 21380

Description:

empty

Owned by:

Beyond Robotics

Add team members:

Member

Add

- Email: contact@beyondrobotics.org
- Insta: @beyond_robotics_team
- Website: beyondrobotics.org
- Tiktok: @beyond21380
- Connections Lead Discord: et.z

Thanks for Listening

Any questions?